

Materialized Optimization of Connecting Rod for Four Stroke Single Cylinder Engine

¹, Marthanapalli HariPriya, ², K.Manohar Reddy

¹m.Tech (Me), Intl- Anantapur (Dt), Affiliated To Jntua University, Andhra Pradesh, India.

² Assistant Professor, Department Of Me, Intell Engg. College Anantapur (Dt), Affiliated To Jntua University, Andhra Pradesh, India.

ABSTRACT

Connecting rods for automotive applications are typically manufactured by forging from either wrought steel or powdered metal. They could also be cast. An optimization study was performed on a steel forged connecting rod with a consideration for improvement in weight and production cost. For this optimization problem, the weight of the connecting rod has little influence on the cost of the final component. Change in the material, resulting in a significant reduction in machining cost, was the key factor in cost reduction. This study has two aspects. The first aspect was to investigate and to compare fatigue strength of steel forged connecting rods with that of the powder forged connecting rods. The second aspect was to optimize the weight and manufacturing cost of the steel forged connecting rod. Constraints of fatigue strength, static strength, reducing inertia loads, reducing engine weight, improvised engine performance, fuel economy were also imposed. The fatigue strength was the most significant factor in the optimization of the connecting rod.

KEYWORDS: PM Connecting rod, fatigue behavior, forged steel.

I. INTRODUCTION

Connecting rod is among large volume production component in the internal combustion engine. It connects the piston to the crankshaft and is responsible for transferring power from the piston to the crankshaft and sending it in to transmission. They are different types of materials and production methods used in the creation of connecting rods. The major stresses induced in the connecting rod are a combination of axial and bending stresses in operation. The axial stresses are produced due to cylinder gas pressure (compressive only) and the inertia force arising in account of reciprocating action (both tensile as well as compressive), where as bending stresses are caused due to the centrifugal effects. It consists of a long shank, a small end and a big end. The cross-section of the shank may be rectangular, circular, tubular, I-section or H-section. Generally circular section is used for low speed engines while I-section is preferred for high speed engines. The most common type of manufacturing processes is casting, forging, and powdered metallurgy. Connecting rod is subjected to a complex state of loading. It undergoes high cyclic loads of the order of 10^8 to 10^9 cycles, which range from high compressive loads due to combustion, to high tensile loads due to inertia. Therefore, durability of this component is critical importance. Due to these factors, the connecting rod has been the topic of research for different aspects such as production technology, materials, performance, simulation, fatigue etc. In modern automotive internal combustion engines, the connecting rods are most usually made of steel for production engines, but can be made of aluminum (for lightness and the ability to absorb high impact at the expense of durability) or titanium (for a combination of strength and lightness at the expense of affordability) for high performance engines, or of cast iron for applications such as motor scooters. They are not rigidly fixed at either end, so that the angle between the connecting rod and the piston can change as the rod moves up and down and rotates around the crankshaft. The small end attaches to the piston pin, gudgeon pin or wrist pin, which is currently most often press fit into the con rod but can swivel in the piston, a "floating wrist pin" design. The big end connects to the bearing journal on the crank throw, running on replaceable bearing shells accessible via the con rod bolts which hold the bearing "cap" onto the big end.

A major source of engine wear is the sideways force exerted on the piston through the con rod by the crankshaft, which typically wears the cylinder into an oval cross-section rather than circular, making it impossible for piston rings to correctly seal against the cylinder walls. Geometrically, it can be seen that longer con rods will reduce the amount of this sideways force, and therefore lead to longer engine life.

However, for a given engine block, the sum of the length of the con rod plus the piston stroke is a fixed number, determined by the fixed distance between the crankshaft axis and the top of the cylinder block where the cylinder head fastens; thus, for a given cylinder block longer stroke, giving greater engine displacement and power, requires a shorter connecting rod, resulting in accelerated cylinder wear.

The automobile engine connecting rod is a high volume production, critical component. It connects reciprocating piston to rotating crankshaft, transmitting the thrust of the piston to the crankshaft. Every vehicle that uses an internal combustion engine requires at least one connecting rod depending upon the number of cylinders in the engine. Connecting rods for automotive applications are typically manufactured by forging from either wrought steel or powdered metal. They could also be cast. However, castings could have blow-holes which are detrimental from durability and fatigue points of view. The fact that forgings produce blow-hole-free and better rods gives them an advantage over cast rods. Between the forging processes, powder forged or drop forged, each process has its own pros and cons. Powder metal manufactured blanks have the advantage of being near net shape, reducing material waste. However, the cost of the blank is high due to the high material cost and sophisticated manufacturing techniques. With steel forging, the material is inexpensive and the rough part manufacturing process is cost effective. The first aspect was to investigate and compare fatigue strength of steel forged connecting rods with that of the powder forged connecting rods. The second aspect was to optimize the weight and manufacturing cost of the steel forged connecting rod. Due to its large volume production, it is only logical that optimization of the connecting rod for its weight or volume will result in large-scale savings. It can also achieve the objective of reducing the weight of the engine component, thus reducing inertia loads, reducing engine weight and improving engine performance and fuel economy.

II. MODELING

The structural and modal analysis of connecting rod for both Aluminium Alloy A360 and Carbon steel are shown as below:

Structural Analysis Of Connecting Rod -Section Using Aluminium Alloy A360

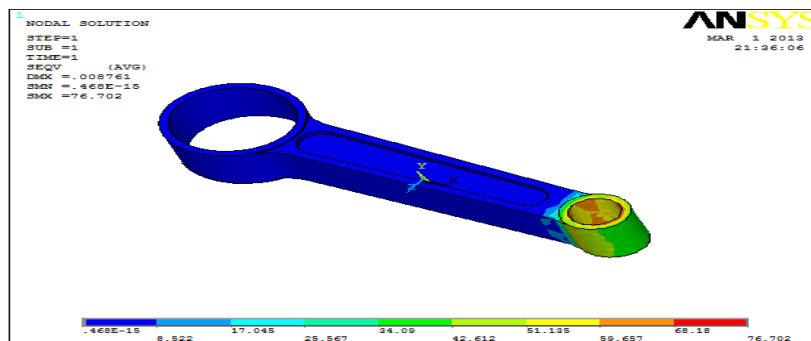

Fig 1.Structural Analysis of connecting rod I-section using Aluminium Alloy A360 ,Young’s modulus – 80000MPa Poisson ratio - 0.33, Density – 0.0000026kg/mm³

Modal Analysis Of Connecting Rod I-Section Using Aluminium Alloy A360

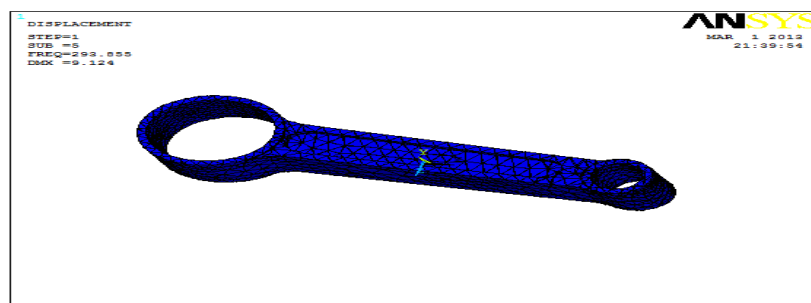

Fig 2.Modal Analysis of connecting rod I-section using Aluminium Alloy A360 ,Young’s modulus – 80000MPa Poisson ratio - 0.33, Density – 0.0000026kg/mm³

Structural Analysis Of Connecting Rod I-Section Using Carbon Steel

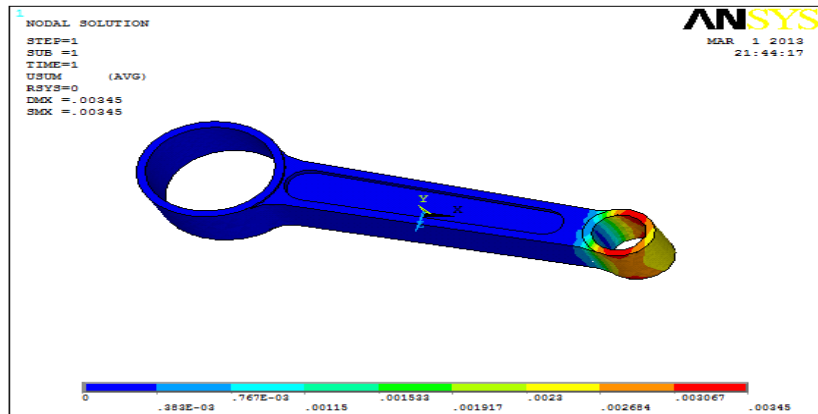

Fig 3. Structural Analysis of connecting rod I-section using Carbon steel ; Young's modulus - 200000MPa,Poisson ratio – 0.295, Density – 0.000007872kg/m3

Structural Analysis Of Connecting Rod H-Section Using Carbon Steel

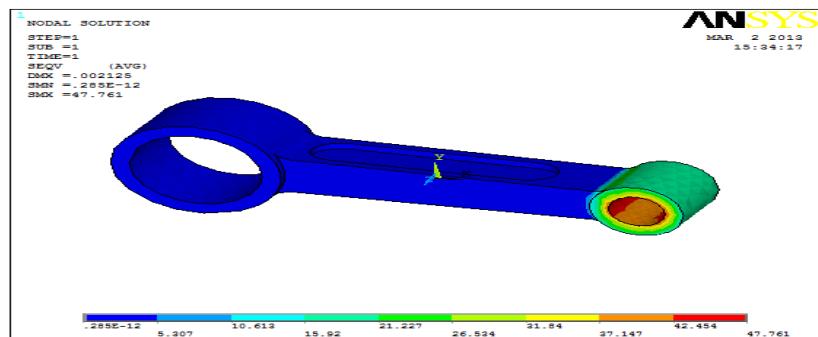

Fig 4.Structural Analysis of connecting rod H-section using Carbon Steel Young's modulus - 200000MPa,Poisson ratio – 0.295, Density – 0.000007872kg/m3

Modal Analysis Of Connecting Rod I-Section Using Carbon Steel

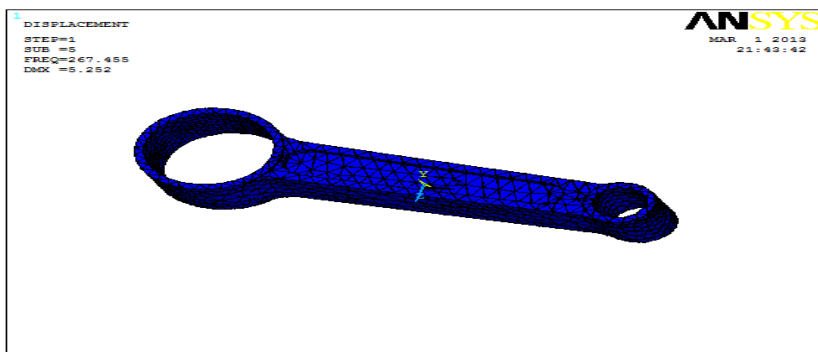

Fig 5.Modal Analysis of connecting rod I-section using Carbon Steel Young's modulus -200000MPa,Poisson ratio – 0.295, Density – 0.000007872kg/m3

Modal Analysis Of Connecting Rod H-Section Using Carbon Steel

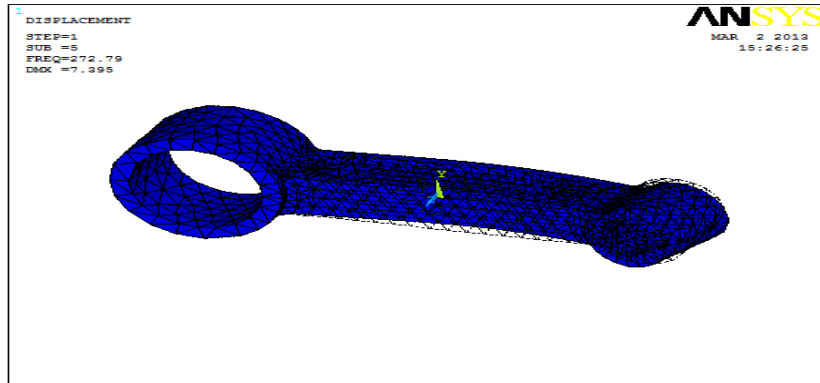

Fig 6. Modal Analysis of connecting rod H-section using Carbon Steel , Young’s modulus - 200000MPa,Poisson ratio – 0.295, Density – 0.000007872kg/m3

III. RESULTS SECTION

		ALUMINUM	CARBON STEEL
	STRESS	47.73	47.761
	(N/mm ²)		
	DISPLACEMENT (mm)	0.05383	0.02125
MODE	FREQUENCY (HZ)	30.109	27.33
	DISPLACEMENT(mm)	6.751	3.88
	FREQUENCY (HZ)	50.47	45.809
	DISPLACEMENT(mm)	6.652	3.823
	FREQUENCY (HZ)	136.825	125.827
	DISPLACEMENT(mm)	9.278	5.332
	FREQUENCY (HZ)	176.617	160.362
	DISPLACEMENT(mm)	6.133	3.53
	FREQUENCY (HZ)	272.79	248.324
	DISPLACEMENT(mm)	7.395	4.255

H-SECTION

		ALUMINUM	CARBON STEEL
	STRESS	76.702	76.644
	(N/mm ²)		
	DISPLACEMENT (mm)	0.008761c	0.00345
MODE	FREQUENCY (HZ)	52.694	47.805
	DISPLACEMENT(mm)	7.158	4.114
	FREQUENCY (HZ)	59.346	53.893
	DISPLACEMENT(mm)	7.093	4.076
	FREQUENCY (HZ)	211.289	194.488
	DISPLACEMENT(mm)	9.429	5.42
	FREQUENCY (HZ)	242.591	220.275
	DISPLACEMENT(mm)	9.516	5.5
	FREQUENCY (HZ)	293.855	267.455
	DISPLACEMENT(mm)	9.124	5.252

IV. CONCLUSION

In this paper, a connecting rod for a 150cc engine has been modeled in 3D modeling software Pro/Engineer. The actual cross section connecting rod is I – section, which have been changed to cross section H – section. By changing the cross section, the weight of connecting rod is reduced by 10gms. The material used for connecting rod is carbon steel which is replaced with Aluminum alloy A360. By replacing it with Aluminum alloy A360, the weight of the connecting rod reduces about 4 times than using Carbon steel since density of Aluminum alloy A360 is very less as compared with Carbon Steel. The structural and modal analysis on the connecting rod using two materials Carbon steel and Aluminum alloy A360 has been done and is concluded that the stress values obtained for both materials are less than their respective yield stress values. So using Aluminum alloy A360 is safe. By comparing the stress values for both materials, it is slightly less for Aluminum alloy A360 than carbon steel. By observing the results, We can conclude that Aluminum alloy A360 is better for connecting rod.

REFERENCES

- [1] A Textbook of Machine Design by R.S.KHURMI AND K.GUPTA.
- [2] Engineering_fundamentals_of_the_internal_combustion_engine by Willard W. Pulkrabek.
- [3] Mechanical Engineering Design by Budynas–Nisbet.
- [4] Automotive Engineering by Patric GRANT.
- [5] Handbook of mechanical engineering - modern manufacturing by Ed. Frank Kreith.
- [6] Engineering Fundamentals of the Internal Combustion Engine by Willard W. Pulkrabek.