

Automated Transportation Mechanism and Obstacle Detection

Vinita Mathur¹, Dr. Rajesh Kumar², Mr. Aniruddhu Gautam²

¹M.Tech Student of AKG Engineering College, Ghaziabad

²Faculty AKG Engineering College, Ghaziabad

ABSTRACT:

The automotive sector is widely recognized as one of the industries with greatest importance and can assume in the development of a country economy this master's thesis is about the implementation and evaluation of Automated Transportation mechanism and Obstacle Detection. By using a real time visual basic concept. A concept of automated transportation by a cooperative which enable robots to process a complicated or heavy duties task and over the large abstraction in the environment a method transportation utilizing forklift mechanism for lifting process and moving process. The path is store in memory by the programmer, the motion of the vehicle is controlled by stepper motor and controlling of the machine is done by micro- controller. Autonomous robotic vehicle guidance has been developed for industrial difficult.

KEYWORDS: Automated guided vehicles; IR sensors; zigbee transmitter; zigbee receiver microcontroller.

I. INTRODUCTION

Now a day's industries are highly automated for various applications. Automated guided vehicles are now widely used in many industries due to the high level of performance and reliability. All guided vehicles feature some kind of obstacle avoidance. The functions of guided vehicles is to carrier a material and deliver products from one manufacturing point to another; where rail, conveyer and gantry systems are not a suitable option. Designing autonomous vehicle requires the integration of many sensors and actuators according to their task. Obstacle detection is primary requirement for any autonomous vehicle. The vehicle acquires the information from the outside environment and process it according to the sensor mounted over it. Various types of sensors are use for the obstacle detection which is ultrasonic sensors, laser sensor, bump sensors, infrared sensors and soon can be used. Among these entire sensor infra red sensor is most suitable because of its low cost and ranging capability. The guidance systems consist of infra red sensor for obstacle detection, range determination and avoidance the unit is highly resistant to ambient light and nearly impervious to variations in the surface reflectivity of the detected object. It can detect the obstacle within the range of 10 to 80 cm. These systems consist of infra red sensor and micro-controller the sensor is mounted on the vehicle to acquire the information from its surrounding. The infra red sensor is most suitable because of its low cost and ranging capability. The performance measurements indicated by the zigbee software using visual basic which provide the wireless communication for the long distance. Background theories and techniques of Electronic control Technology and analyzed in this paper using both hardware and software consideration.

II. SYSTEM DESCRIPTION

This vehicle is designed to detect the obstacle and avoiding collision base on the distance measurement information obtained from the infra red sensors. Hardware circuit of Automated Transportation mechanism and Obstacle Detection consist of two parts transmission of data though transmitter circuit which consist of zigbee transmitter and a receiver circuit which called as zigbee receiver which receives the data entry though the programmer. Receiver circuit also consists of an IR Sensor which is connected to the microcontroller for obstacle detection. The transmitter circuit is consist of an zigbee transmitter and power regulator LM317 for 3.3V and db 9 connector though pin no. 13 & 14 of the IC in which 5V supply is provides to data is enter though the programmer. Circuit diagram of transmitter is shown in fig 1. Here the data is received by the zigbee receiver which is controlled though the microcontroller IC AT89S52 which control the movements of the motors and up-down movements of the rack and pinion though the relay IC ULN 2003 which is connected to the six motor and the six coil the ULN2003 send the signal according to which the motor movement are decided. Here, an obstacle detection IR (Infrared sensor) sensor is also used for the detection of obstacle during the

loading and unloading of the material which is connected to the pin no. 5 of microcontroller. As shown in block Diagram of the system shown below

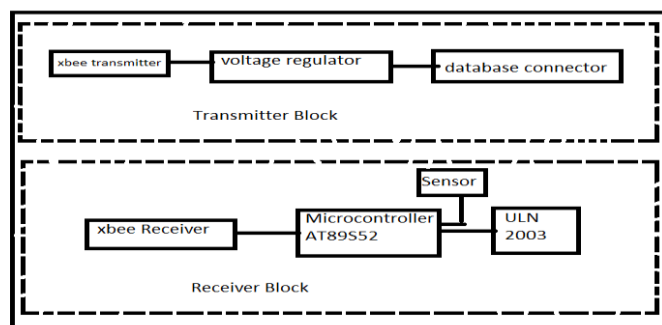

Fig 1 Block dig of Automated guided vehicle and obstacle detection

III. BASIC DESIGN AND ITS REQUIREMENTS

A) The microcontroller

The AT89C52 is a low-power, high-performance CMOS 8-bit microcomputer with 8K bytes of Flash programmable and erasable read only memory (PEROM). The device is manufactured using Atmel's high-density nonvolatile memory technology and is compatible with the industry-standard 80C51 and 80C52 instruction set and pin out. The on-chip Flash allows the program memory to be reprogrammed in-system or by a conventional nonvolatile memory programmer. By combining a versatile 8-bit CPU with Flash on a monolithic chip, the Atmel AT89C52 is a powerful microcomputer which provides a highly-flexible and cost-effective solution to many embedded control applications. The AT89C52 provides the following standard features: 8K bytes of Flash, 256 bytes of RAM, 32 I/O lines, three 16-bit timer/counters, a six-vector two-level interrupt architecture, a full-duplex serial port, on-chip oscillator, and clock circuitry.

B) IR sensor

The digital IR sensor consists of an IR transmitter, IR receiver, and an Op-Amp. Once powered, IR LED continuously keeps emitting IR light. Hence the IR LED acts as transmitter and the photodiode acts as receiver. As soon as the IR radiation is reflected back by a surface, it is absorbed by the receiver (photodiode). A standard op-amp operating in open loop configuration (without any feedback) can be used as a comparator. When the non-inverting input voltage (V_1) is higher than the inverting input voltage (V_2), the high gain of the op-amp causes it to output the most positive voltage, i.e. the output of the op-amp will be high (1). When the non-inverting input voltage (V_1) drops below the inverting input voltage (V_2), the op-amp outputs the most negative voltage, i.e. the output of the op-amp will be low (0).

C) Design and calculation of motor:

		#1	#2	#3
Voltage, V	V	1.5	3	6
No-load speed, ω	rpm	13,400	5,400	4,700
Stall torque, T_s	N-m	0.0003	0.0016	0.007
No-load current, I	A	0.02	0.016	0.01
Terminal resistance, R	Ω	5	9.5	10
Torque constant, K_t	N-m/A	0.001	0.005	0.012
Length	mm	17	21	31
Diameter	mm	8	16	23

IV. MOTOR CALCULATION

D) Voltage Regulator

Voltage regulator is used as voltage regulator in this line follower. This is applied to maintain constant output voltage. Generally it consists of 3 terminals one input one output terminals and another one is ground terminal. The output terminal is then connected to the power supply pin of the microcontroller. It looks like a transistor but it is actually an integrated circuit with 3 legs. It can take a higher, crappy DC voltage and turn it into a nice, smooth 5 volts DC.

Voltage regulator.

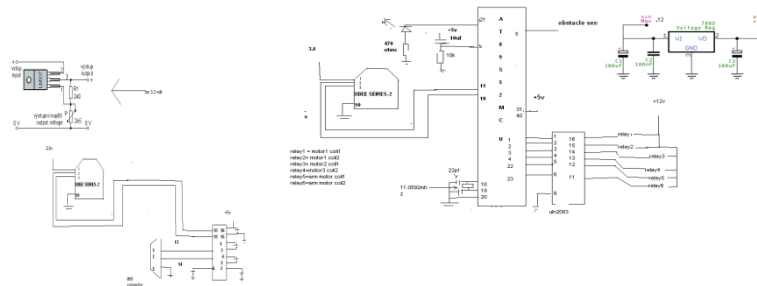

Fig 2 Transmitter and Receiver circuit

IV. CONSIDERATION OF RULES FOR OBSTACLE AVOIDING

1) Path predetermining state

The system must be pre limited for going straight distance, turning left or right and returning back straight to the starting point for no obstacles condition.

2) Obstacle is detected at the left

Stop for a while one or both sensors are detected. The system must turn to right and check if there is any obstacle or not in this turning state. It must return to left and go straight at normal position.

3) Obstacle is detected at the right

The system must be stop for a whether one or both right sensor are detected. It must turn to left and check if there is any obstacle or not in this turning state. And then it will return to right and go straight at normal position.

V. V SOFTWARE IMPLEMENTATION

The focus of network applications under the IEEE 802.15.4 / ZigBee standard include the features of low power consumption, needed for only two major modes (Tx/Rx or Sleep), high density of nodes per network, low costs and simple implementation.

These features are enabled by the following characteristics

- [1] 2.4GHz and 868/915 MHz dual PHY modes.
- [2] This represents three license-free bands: 2.4-2.4835 GHz, 868-870 MHz and 902-928 MHz The number of channels allotted to each frequency band is fixed at 16 channels in the 2.45 GHz band, 10 channels in the 915 MHz band, and 1 channel in the 868 MHz band
- [3] · Maximum data rates allowed for each of these frequency bands are fixed as 250 kbps @2.4 GHz, 40 kbps @ 915 MHz, and 20 kbps @868 MHz.
- [4] Allocated 16 bit short or 64 bit extended addresses.
- [5] Allocation of guaranteed time slots (GTSs)
- [6] Carrier sense multiple access with collision avoidance (CSMA-CA) channel
- [7] Access Yields high throughput and low latency for low duty cycle devices like sensors and controls.
- [8] Fully "hand-shake" acknowledged protocol for transfer reliability.
- [9] Low power consumption with battery life ranging from months to years.
- [10] Energy detection (ED).
- [11] Link quality indication (LQI).
- [12] Multiple topologies : star, peer-to-peer, mesh topologies

C51 COMPILER V6.03, COMPILATION OF MODULE MAIN OBJECT MODULE PLACED IN
 \MAIN.OBJCOMPILER INVOKED BY: C:\Keil\C51\BIN\C51.EXE \MAIN.C DEBUG OBJECTEXTEND

Stmt level source

```

1  #include"reg52.h"
2
3
4  #define F 1
5  #define B 2
6  #define L 3
7  #define R 4
8  #define S 5
9  #define U 6
10 #define D 7
11
12 sbit motor1_coil1=P1^0;
13 sbit motor1_coil2=P1^1;
14 sbit motor2_coil1=P1^2;
15 sbit motor2_coil2=P1^3;
16
17 sbit arm_coil1=P2^1;
18 sbit arm_coil2=P2^2;
19
20
21 sbit obstacle=P1^4;
22 sbit led=P2^0;
23 unsigned char alarm1=0;
24 unsigned char alarm2=0;
25 unsigned char alarm3=0;
26
27 void forward ();
28 void reverse ();
29 void left ();
30 void right ();
31 void stop ();

```

VI. CONCLUSION

A complete and reliable sensing system for obstacle detection can benefit a lot from the combined use of sensors. Any one particular type of technology may have difficulties to meet all necessary requirements in order to detect an obstacle in various lighting or weather condition. The path is store in memory by the programmer, the motion of the vehicle is controlled by stepper motor and controlling of the machine is done by micro- controller. Autonomous robotic vehicle guidance has been developed for industrial difficult. The guidance systems consist of infra red sensor for obstacle detection, range determination and avoidance. It can detect the obstacle within the range of 10 to 80 cm. These systems consist of infra red sensor and micro-controller the sensor is mounted on the vehicle to acquire the information from its surrounding. The infra red sensor is most suitable because of its low cost and ranging capability. The performance measurements indicated that the visual basic was fast but also had a slightly larger jitter.

REFERENCES

- [1] Aziz, A.R.A., *Designing and Constructing an Automatic Steering Vehicle (AGV)*, in *Dept of Electrical Engineering*. 2004, University Tenaga National: Malaysia. p. 50.
- [2] Wai Phyo Aung, *Software Implementation of Obstacle Detection and Avoidance System for Wheeled Mobile Robot*.2008
- [3] Ross, K. 2004. Analog and Digital Sensors
- [4] Mehran pakdaman, Design and Implementation of line follower Robot.2009,Tabari Institute of Babol.
- [5] A.Kahe "AT89S52 Architecture,"nas publication,2008.
- [6] M.Mashaghi,robotic guide,Kanone Oloum Publication,2008
- [7] Wikipedia, Mobile robots.
- [8] Cao Quoc Huy, line follower, University UPG din Ploiesti, nr 39 Bld Bucuresti, Ploiesti.